

H175

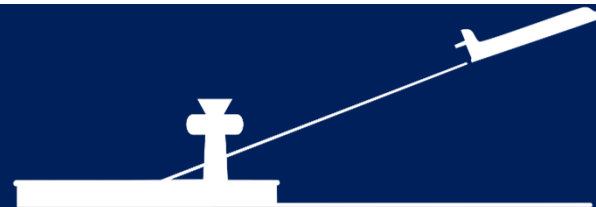

SOLAKONFERANSEN September 20th, 2021

AIRBUS

This document is the property of Airbus Helicopters; no part of it (including its content) shall be reproduced or transmitted without the express prior written authorization of Airbus Helicopters. © Airbus Helicopters – All rights reserved.

The facts and figures contained in this document are disclosed for information purposes only. Airbus Helicopters reserves the right to make configuration and data changes at any time without notice. This document does not constitute any offer or contract with Airbus Helicopters

H175 | FLEET OVERVIEW

- 48 helicopters delivered
- 35 in O&G configuration are flying in UK / Netherlands / Denmark / Mexico / Timor and Brazil
- More than 116,000 FH cumulated including more than 11,000 FH for Public Services
- Fleet leader is above + 6,400 FH
- 3 H175 prototypes continue to perform flights to expand the product capabilities



H175

SAFETY AS A PARAMOUNT



H175 | PILOT DISORIENTATION PROTECTION RECOVERY MODE





H175 | HELIPAD ASSISTED TAKE-OFF





H175 | VORTEX RING PROTECTION COUPLED WITH AFCS

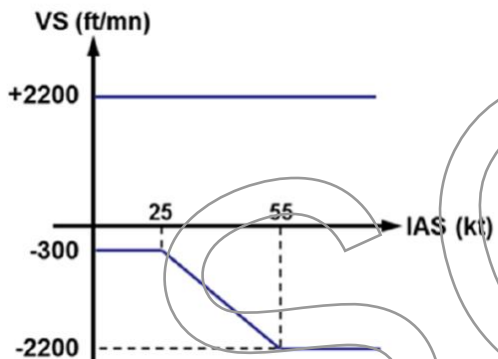

- The VORTEX protection limits the rate of descent with a vertical mode coupled in 3-axis or 4-axis.
- The maximum commanded rate of descent decreases with airspeed to avoid VORTEX conditions.



H175 | VORTEX CAUTION MANUAL FLIGHT



2021



3 audio messages
"CHECK POWER"



H175 | VORTEX ALARM MANUAL FLIGHT

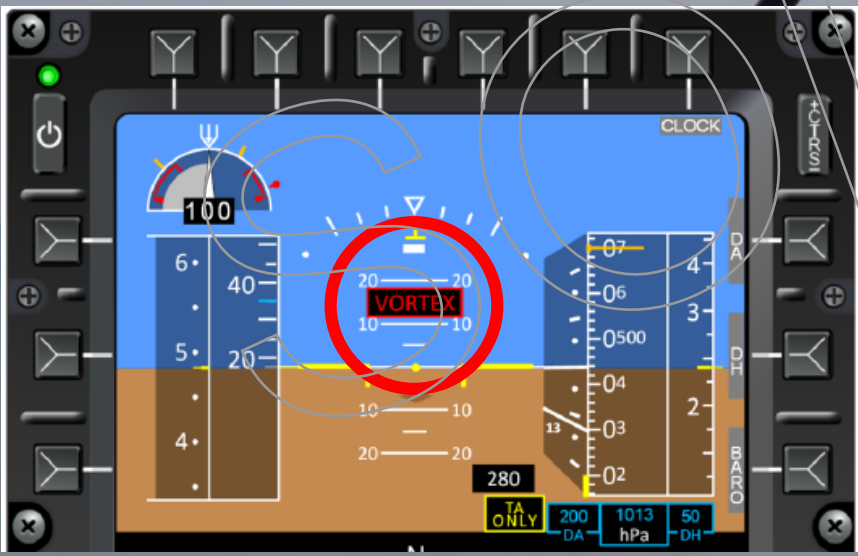

audio message
"VORTEX VORTEX"

H175 | OIL RIG APPROACH ASSISTANCE RIG'N FLY

3 types of approach

- Crew selection of:
- O/S destination
 - Type of approach
 - Approach course
 - MDA
 - Lateral offset side
 - ALT.A set and armed

No visual on rig:
=> Fully automated missed approach procedure
=> Single push on Go Around button

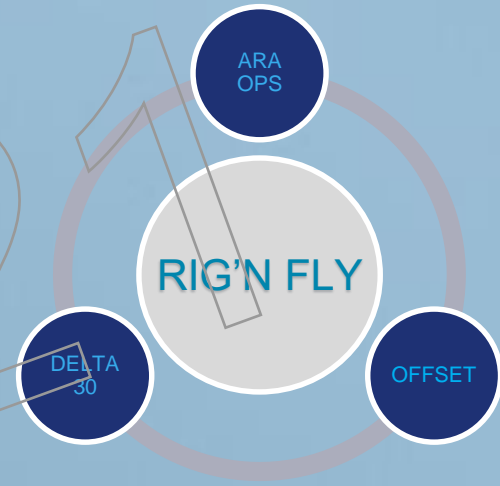

RIG'N FLY enhances offshore operations with valuable awareness and safety features

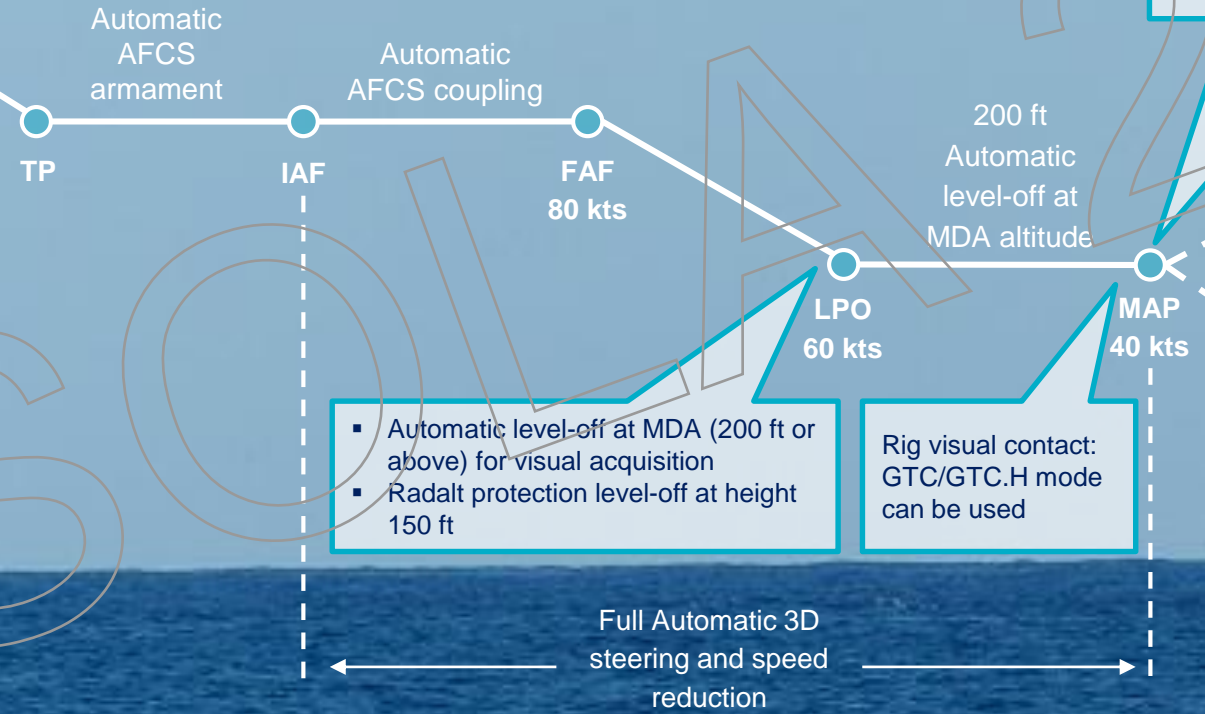

H175

FULL DE-ICING ON TRACK

H175

FULL ICING PROTECTION SYSTEM IN DEVELOPMENT

The H175 is certified down to -40°C. Flights in icing conditions are not permitted unless the h/c is equipped with:

Already certified

Flight in Limited Icing Conditions (FLIC)

- Heated Windshield
- Ice detector
- Air intake protection
- Stabilizer protection

In development

Full Icing Protection System (FIPS)

- Heated main rotor blades
- Heated tail rotor blades
- Summer kit

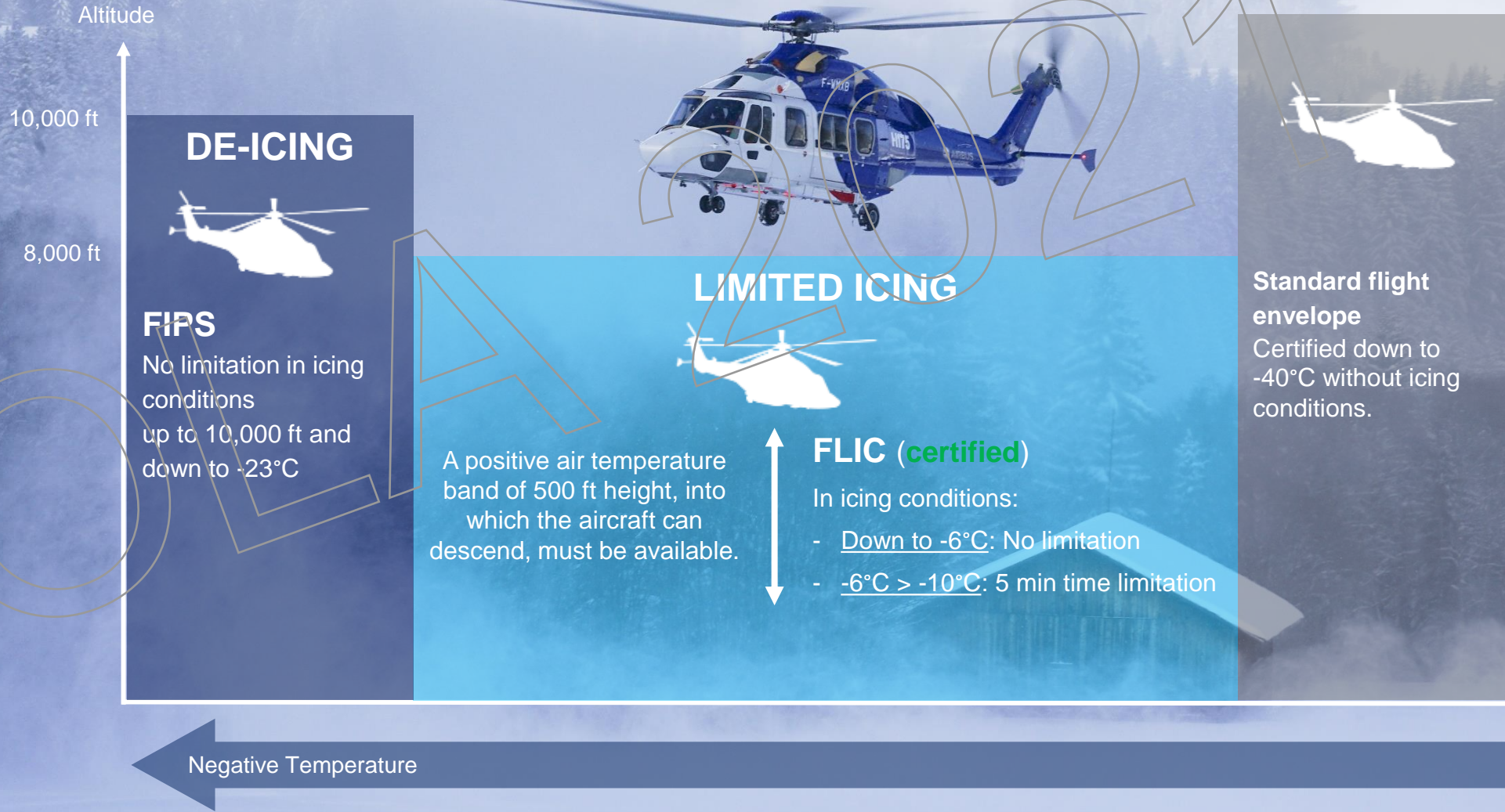



H175 | FIPS DEVELOPMENT & PLANNING

2020

2021

2022

2023



Pre-development

Development

Industrialization

Final certification

Prototype Campaign

First Winter Campaign

Second Winter Campaign

H175

READY FOR NORWAY

H1175 | MISSION RANGE NORWAY

14 PAX

Number of platforms by distance

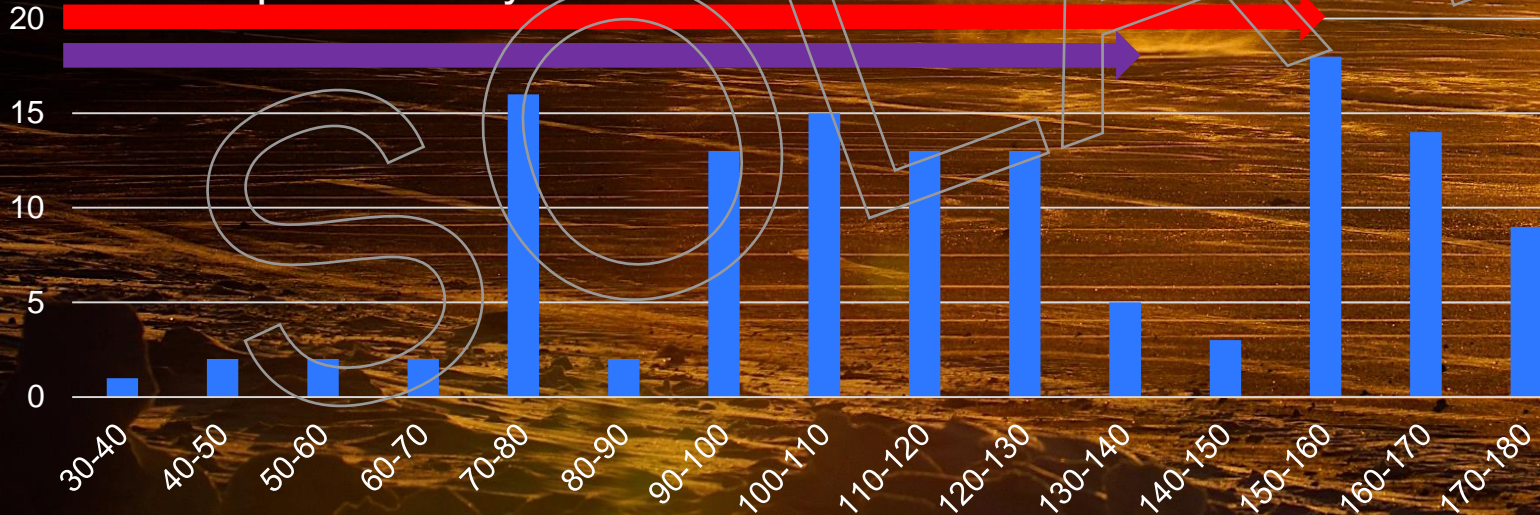

■ Summer Kit → 82%

■ Winter Kit → 66%

With 14 PAX

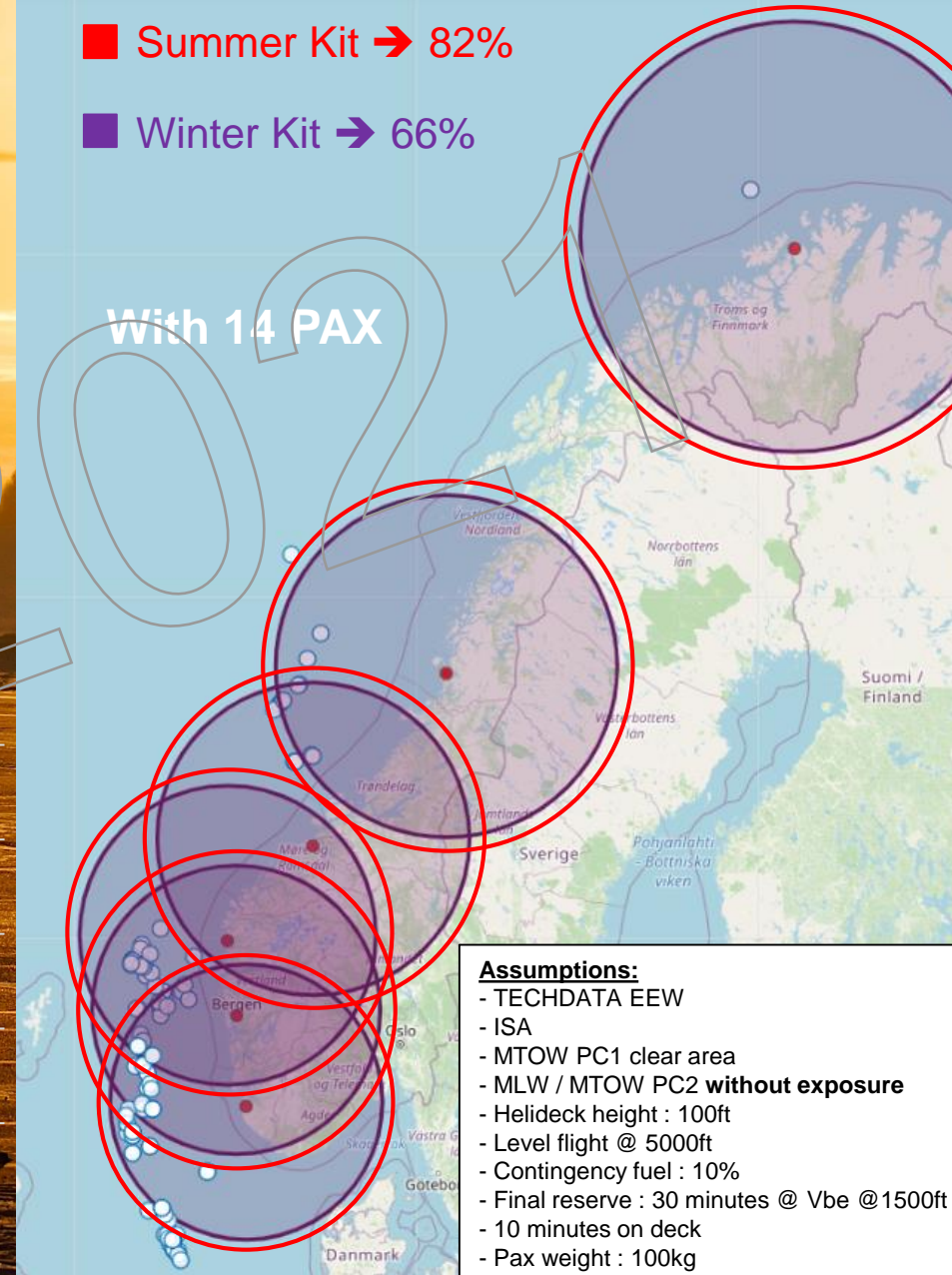

Assumptions:

- TECHDATA EEW
- ISA
- MTOW PC1 clear area
- MLW / MTOW PC2 **without exposure**
- Helideck height : 100ft
- Level flight @ 5000ft
- Contingency fuel : 10%
- Final reserve : 30 minutes @ Vbe @ 1500ft
- 10 minutes on deck
- Pax weight : 100kg

H175 | MISSION RANGE NORWAY



100 % of platforms
reachable with at least :

- 11 pax → Winter Kit
- 12 pax → Summer Kit

Number of platforms by distance

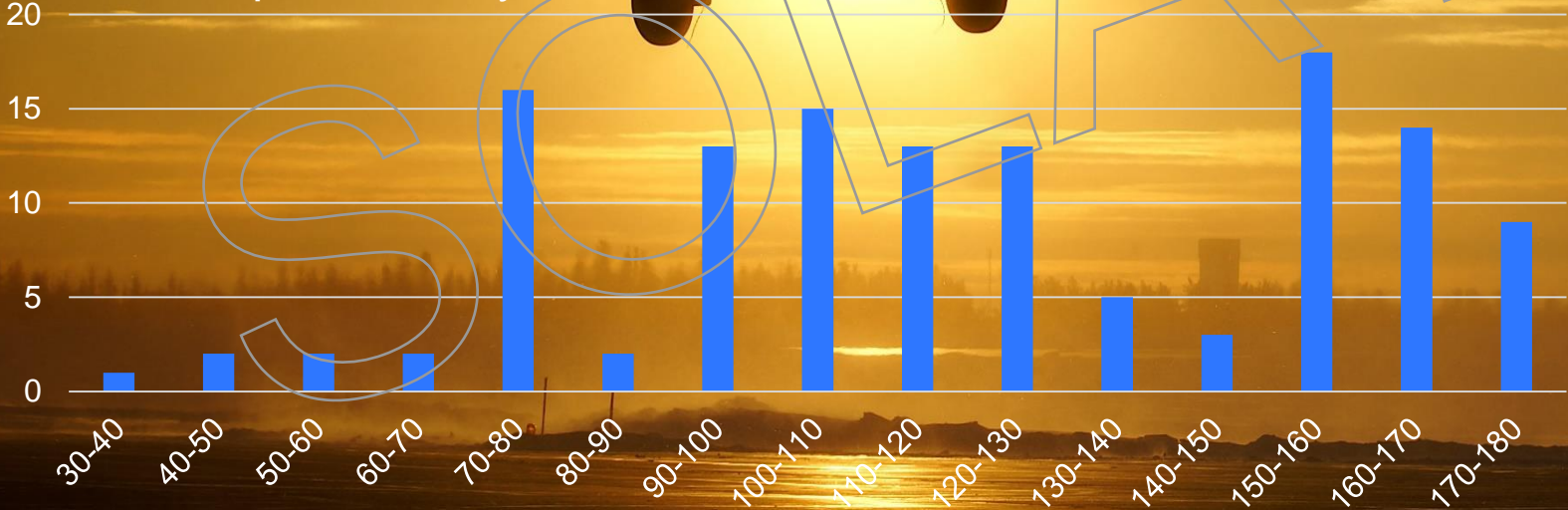

H175



ONE MORE THING

H175 | FLY WITH SAF

- All Airbus helicopters are already certified to run with a blend of as much of 50% SAF in the kerosene.
- We, Airbus, believe this is the right thing to do to proactively accelerate the use of blended SAF kerosene in order to pave the way for a 100% SAF fuel in the future.

SOLOA 2021

Thank you

This document is the property of Airbus Helicopters; no part of it (including its content) shall be reproduced or transmitted without the express prior written authorization of Airbus Helicopters. © Airbus Helicopters – All rights reserved.

The facts and figures contained in this document are disclosed for information purposes only. Airbus Helicopters reserves the right to make configuration and data changes at any time without notice. This document does not constitute any offer or contract with Airbus Helicopters